



AUT
AN EKOSCAN COMPANY

INDUSTRIAL SCANNERS

MANUAL

—————
AUTOMATED

—————
ON-SPEC



AN EKOSCAN COMPANY

Your partner in industrial scanning solutions

Manual, semi-automated, motorized and tailored scanners for NDT

With years of senior technical expertise, we deliver advanced Non-Destructive Testing (NDT) equipment, services, and support.

We empower various industries with systems and expertise to ensure and manage assets integrity.

Contents

AUTOMATED SCANNERS

ACCUTRAK – 3-axis corrosion and weld inspection	05
R-MOT – 2-axis internal pipe inspection	09
BANDIT – 2-axis corrosion inspection	11
THERMALSCAN – 2-axis high temperature small diameter pipe inspection	13

MANUAL SCANNERS

WELDSCAN – PAUT & TOFD weld inspection	17
CIRC-SCAN – Multi-purpose pipe inspection	19
REVOLVER – Small diameter pipe inspection	21
NANOSCAN – Multi-purpose inspection	23
MATRYX XY – Lightweight panel mapping inspection	25
MATRYX RT – Lightweight paint-brush inspection	27
HANDSCAN – Smart encoded probe holder	29

ACCESSORIES

PROSCAN XT – Single channel Ultrasonic flaw detector with 2-Axis encoding	33
PROSCAN 8 – 8 channels Ultrasonic flaw detector	33
LASER MAPPER – External Corrosion Mapping Scanner - Laser profilometry	34

AUTOMATED SCANNERS

ACCUTRAK

R-MOT

BANDIT

THERMALSCAN



AUTOMATED SCANNERS

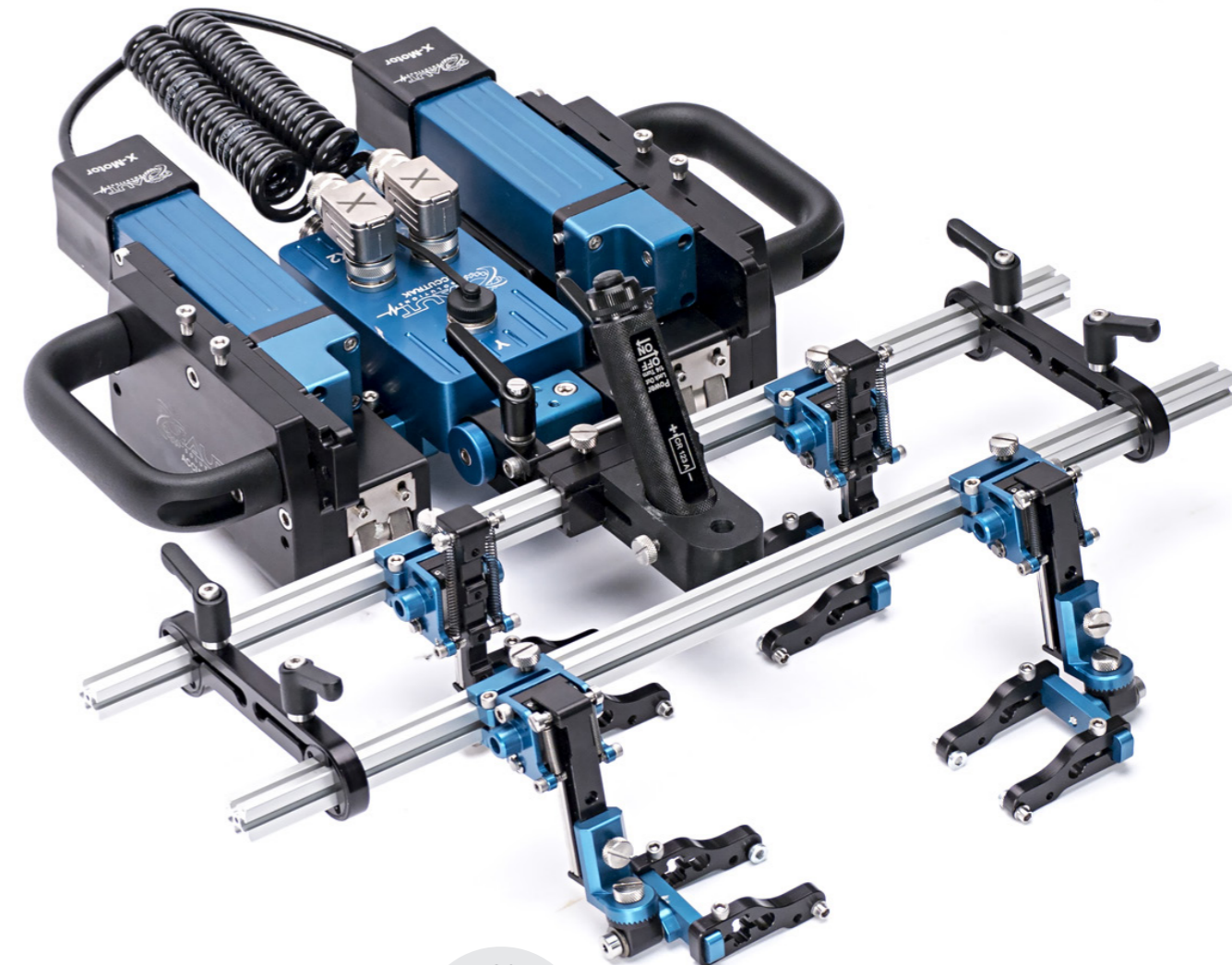



ACCUTRAK

The flagship motorized scanner

Designed for automated weld inspections and corrosion mapping, the ACCUTRAK product series offers versatility and robustness to meet challenging field requirements.

- 1-stop shop
- No rope access nor scaffolding requirement
- Save inspection time
- A unique product for various applications
- Minimum training time for scanner control
- Compatible with your existing NDT device

Proven excellence for corrosion mapping and weld inspection on :



ACCUTRAK - CORROSION MAPPING



The **AccuTrak – Corrosion Mapping** offers advanced performance through its modular and robust design.

Proven excellence for corrosion mapping inspection of tanks, pipes and large panels.

ACCUTRAK - WELD INSPECTION



4-probe weld inspection

The **AccuTrak – Weld Scanning** is the ideal companion for weld inspection with Phased-Array and TOFD.

Proven excellence for weld inspection of pipes, pressure vessels and tanks.

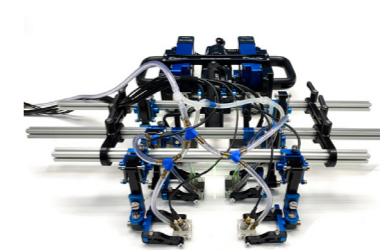

6-probe weld inspection

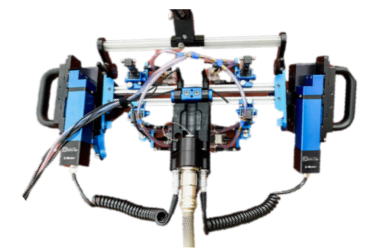

Catamaran

ACCUTRAK - CORROSION BSCAN

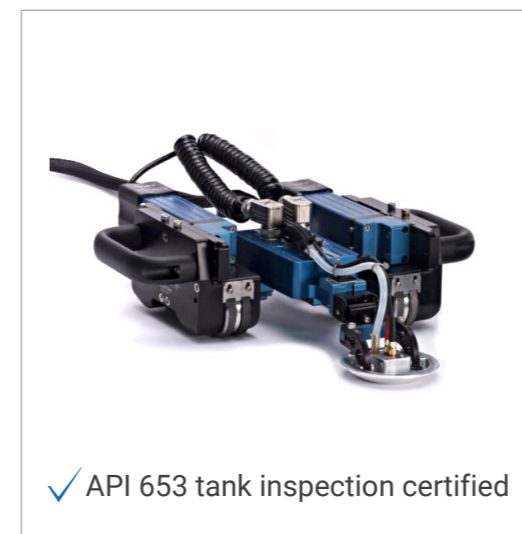

✓ API 653 tank inspection certified

The **AccuTrak – Corrosion BSCAN** offers an easy-to-use remote B-Scan for tank inspection, compliant with API 653.

Proven excellence for thickness measurement of storage tanks.

ACCUTRAK - CORROSION MAPPING

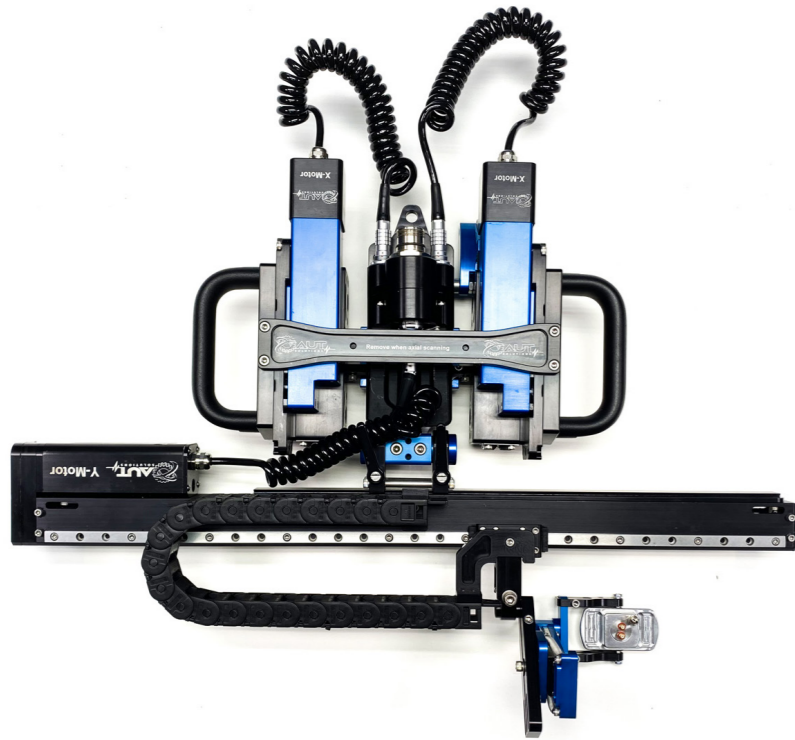

Modular design

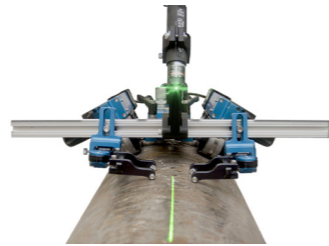

Axial Scanning - Laser guided

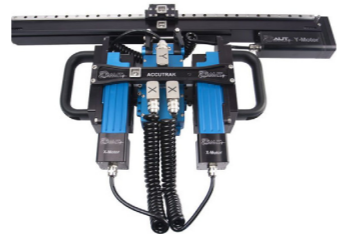

3-Axis - Remote corrosion mapping



2-Axis - Weld exams / Line B-Scans

Features

- Steerable automated scanner – up to 3-axis
- Modular design – adaptable to various environment and applications
- Fast inspection – X: 6"/sec – Y: 30"/sec
- Lightweight – less than 17 Lbs / 8 kg
- Reliable – 11 years presence in the field, 200+ units in use
- Technology – UT, PAUT, EMAT, RVT
- Robust – strong magnetic wheels allowing vertical climbing



Scan to find out more about AccuTrak

→ TECHNICAL SPECIFICATION STANDARD KIT

	ACCUTRAK CORROSION BSCAN	ACCUTRAK WELD INSPECTION	ACCUTRAK CORROSION MAPPING
Thickness measurement	✓	✓	✓
Weld inspection		✓	✓
Corrosion mapping			✓
Dimensions (L x W x H)	13.5 x 10.5 x 4.25" 33 x 25 x 10 cm	13.5 x 10.5 x 4.25" 33 x 25 x 10 cm	13.5 x 10.5 x 4.25" 33 x 25 x 10 cm
X-axis Encoder resolution	X: 42725.56 ticks / in (1682 ticks / mm)	X: 42725.56 ticks / in (1682 ticks / mm)	X: 42725.56 ticks / in (1682 ticks / mm)
Y-axis Encoder resolution	-	-	Y: 6666.67 ticks / in (262.47 ticks / mm)
Scan speed	X-axis : 6"/s (150 mm / s)	X-axis : 6"/s (150 mm / s)	X-axis : 6"/s (150 mm / s) Y-axis : 30"/s (762mm / s)
2-axis inspection	✓	✓	✓
3rd axis arm with motor	-	-	✓
Circumferential OD	From 4" / 10 cm	From 4" / 10 cm	From 4" / 10 cm
Axial OD	From 8" / 20 cm	From 8" / 20 cm	From 8" / 20 cm
Spiral weld OD	From 24" / 61 cm	From 24" / 61 cm	From 24" / 61 cm
Turn radius	12" / 30,5 cm	12" / 30,5 cm	12" / 30,5 cm
Joystick	✓	✓	✓
Umbilical default length	100 ft. / 30 m	100 ft. / 30 m	100 ft. / 30 m
Travel case dimensions	32 x 21 x 16"	32 x 21 x 16"	32 x 21 x 16"

→ OPTIONS

	ACCUTRAK CORROSION BSCAN	ACCUTRAK WELD INSPECTION	ACCUTRAK CORROSION MAPPING
Battery autonomy	8 hours	8 hours	8 hours
Spare motors kit (X & Y)	✓	✓	✓
12, 24, 36 and 48" arms	-	✓	✓
Rechargeable battery pack with charger	✓	✓	✓
Catamaran kit	-	✓	-
Fixed probe	✓	-	✓
50 - 200 feet umbilicals	✓	✓	✓
Multi-probe kit for TOFD and PAUT probes	✓	✓	✓
Laser line - green (battery powered)	-	✓	-
Camera 45 ft, USB	✓	✓	✓
Truck extension for ID scanning of 14" pipe	✓	✓	✓
ProScan XT Single Channel 2 axis encoding	✓	-	✓



R-MOT

ID pipe crawler

The R-MOT is an automated scanner designed to inspect pipes from the inside for 12 to 30" diameter and a single truck for 8 to 10" diameter.

- **All-in-one** – Complete solution for pipe inspection from the inside
- **Quick field deployment** – Minimum training operation, easy fix & adjustment
- **Competitive price**
- **Field designed** – Improved durability
- **Compatible** with most probes and flaw detectors

Proven excellence for ID pipe inspection.

R-MOT



Features

- Robust – with high grade anodized aluminium parts
- Compatible – universal probe holders & encoder connection
- Powered – VAC or battery pack for easy deployment
- Adjustable
- Strong magnetic wheels



– Easily adjustable arm width

– Easily adjustable height

→ TECHNICAL SPECIFICATION

GENERAL	
Scanner dimensions	12"x11.5"x12.5" 30 x 28 x 32 cm
Weight	22 Lbs / 10 kg
Operating environment	120°F (49°C) IP65 water resistant
Encoder resolution	42725.56 ticks / in 1682 ticks / mm
Encoder cable	100 ft. / 30 m
Circumferential ID	From 8" / 20 cm to 30" / 76 cm
Travel case dimensions	32 x 25 x 18" 81 x 63 x 46 cm

INCLUDES
<ul style="list-style-type: none"> • 100 ft. umbilical with strain relief • Shipping case • Battery pack • AC/DC power supply • AccuTrak trucks with R-motor • 2 probes or 4 probes (depending on kit) • ProScan XT Single Channel 2 axis encoding • 1-year factory warranty • User manual



Scan to see the R-MOT
in action



BANDIT

Lightweight, compact and low-clearance automated scanner for corrosion mapping

Fueled with innovations, BANDIT is designed for quick deployment and fast corrosion mapping.

- Easy to carry, easy to deploy, easy to pack
- Fits in reduced-access conditions
- Fast inspection
- Easy switch from circular to longitudinal configuration
- No rope access nor scaffolding requirement
- Save inspection time
- Minimum training time for scanner control
- Compatible with your existing NDT device
- 1-stop shop

Proven excellence for inspection of large corrosion mapping areas.

BANDIT

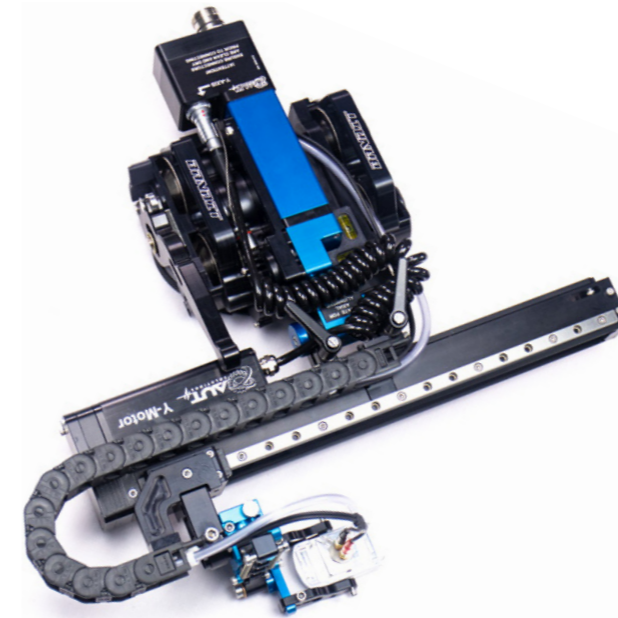

Features

- Compact – 2-axis automated scanner,
- Lightweight and low profile,
- Ergonomics – quick release system
- Versatile – OD circumferential (from 2") & axial (from 6") scan capabilities

→ TECHNICAL SPECIFICATION

GENERAL	
Scanner dimensions (LxWxH)	12 x 7 x 4" 30 x 18 x 10 cm
Weight	10.5 lbs / 4.8 kg
Power	Power supply
Operating environment	IP65 Water Resistant
Encoder resolution	42725.56 ticks / in 1682 ticks / mm
Scan speed	Scanning : 6" / s (150 mm / s) Indexing : 30" / s (762 mm / s)
2-axis inspection	✓
Circumferential OD	From 2" / 5 cm
Axial scanning	From 6" / 15 cm
Motor controller dimensions	6.75 x 5 x 2" 30 x 18 x 10 cm
Probe gimbal / fork	Dual 3/8" 5Mhz
Umbilical	100 ft. / 30 m
Joystick	✓

INCLUDES
<ul style="list-style-type: none"> • 12" arm • 2-axis motor controller • Probe gimbal • Power supply • All windows OS compatible (32 or 64bit) • 100 foot umbilical with irrigation and 6 UT lines

ACCESSORIES / OPTIONS
20", 24" or 36" arms (AS-Arm)
Spare motor / junction box kit
Rechargeable battery pack with charger
25 foot, 200 foot, or custom length umbilicals
ProScan XT Single Channel 2 axis encoding
ProScan 8 Powerful 8 channel with 2 axis encoding
Multi-probe kit for TOFD / Phased Array inspection (KA-WGS)
Rugged integrated motor control / laptop case (EQC-Case)





THERMALSCAN

The high-temperature automated scanner that does not sweat

Automated 2-axis scanner designed with a air cooled system for use on high temperature components up to 700F (371C).

- **Fast** – Scan up to 30"/s on the arm and 5"/s on the wheels
- **Portable** – Entire system fits into three travel cases
- **Modular** – Arms and motors can be switched in minutes
- **Versatile** – Works on 3"+ inch pipe and on surfaces that are up to 700°F
- **High temp magnetic wheels** – High curie point and long lasting
- **Integrated Cooling** – Built in cooling for motors and magnets
- **Compatible** – works with most flaw detectors

Proven excellence for inspection of large corrosion mapping areas.

THERMALSCAN

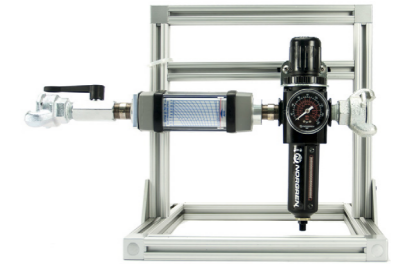

Air regulation system



Shipping case



High temperature magnetic wheels

→ TECHNICAL SPECIFICATION

GENERAL	
Scanner dimensions (L x W x H)	40 x 7 x 6" 101 x 17 x 15 cm
Weight	29 lbs / 13.2 kg
Power	Power supply
Operating environment	Up to 700°F / 371°C
Encoder resolution	36200
Scan speed	Wheel : 6" / s Arm : 30" / s
2-axis inspection	✓
Circumferential OD	From 2" / 5 cm
Axial scanning	From 6" / 15 cm
Motor controller dimensions	6.75 x 5 x 2" 15 x 13 x 5 cm
Probe gimbal / fork	TS Gimbal
Umbilical	100 ft. / 30 m
Joystick	✓

INCLUDES
<ul style="list-style-type: none"> • 24 inch catamaran arm • Air pressure and CFM regulator kit • High temperature air / fluid tubing • 2-axis motor controller • High temp probe gimble • Power supply • All Windows OS compatible (32 or 64bit) • 100 foot umbilical with irrigation and 4 UT lines • 15 foot high temp umbilical extension • Three robust Pelican shipping cases

ACCESSORIES / OPTIONS
<ul style="list-style-type: none"> • 12" or 18" arms (No secondary drive) • Spare motor kit • Rechargeable battery pack with charger • 25 ft., 200 ft., or custom length umbilicals • Multi-probe kit for TOFD/Phased Array • High temperature dual focused transducers



Scan to learn more about ThermalScan

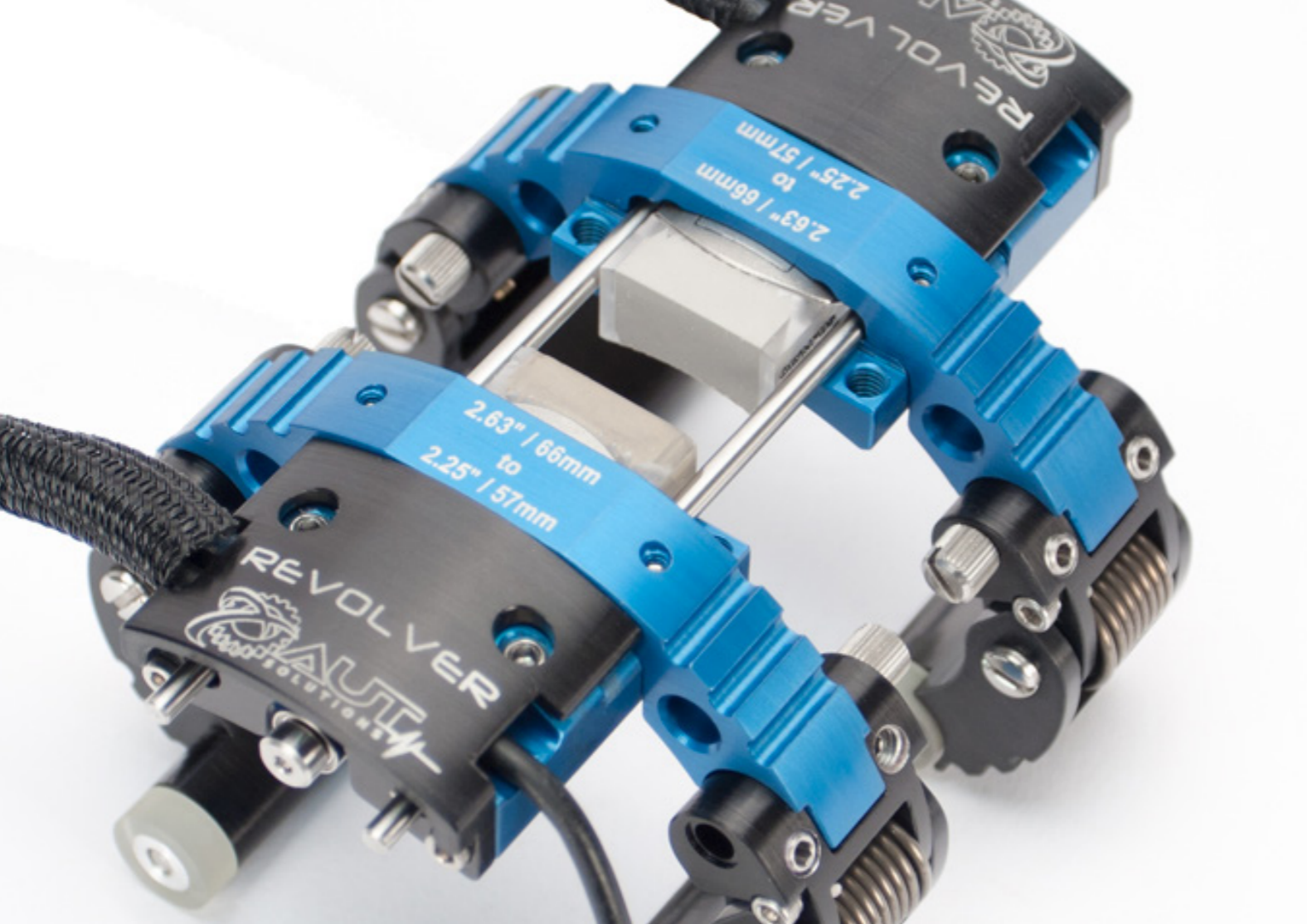

MANUAL SCANNERS

WELDSCAN

CIRC-SCAN

REVOLVER

NANOSCAN

MANUAL SCANNERS





WELDSCAN

The cost-effective PAUT & TOFD scanner for weld inspection

WELDSCAN is a lightweight and compact scanner dedicated to circumferential & axial weld inspection.

- Minimum training operation, easy fix & multiple adjustments possible
- Competitive price
- Durable materials with lifetime warranty for the encoder
- Use existing PAUT probes & units
- Worldwide support

Proven excellence for inspection of circumferential and axial welds.

WELDSCAN



2-Probe configuration

4-Probe configuration

2-Probe Offset configuration

Features

- **Versatile** – inspect circumferential from 6" & axial welds from 10"
- **Configurable** – quick & easy configuration, up to 8 PA probes inspection
- **Compact** – and lightweight for easy operation
- **Compatible** – with most TOFD and PAUT probes and wedges,
- **Rugged** – with high grade anodized aluminium parts with IP68 rated encoder for improved durability

→ TECHNICAL SPECIFICATION

GENERAL	
Scanner dimensions	6.5 x 4.4 x 18" 15 x 10 x 46 cm
Weight	5.5 lbs / 2.3 kg
Operating environment	Up to 500°F / 260°C
Encoder type	RME-688-1000p
Encoder resolution	1273 / in (50.15 / mm)
Encoder cable length	15 ft / 5 m
Encoder connector	Compatible with commercial flaw detectors
Travel case dimensions	24 x 16 x 10.5" 61 x 41 x 25 cm

INCLUDES
<ul style="list-style-type: none"> • Circumferential & Axial Scanning • IP68 Waterproof encoder w/ lifetime warranty • Detachable encoder cable (offered in various lengths) • Soft surface magnetic wheels • Quick & easy configuration changes • 4 x Stage -1 linear gimbles for perfect probe alignment • 1 straight 18" arm 1 hinged 18" arm 4 US-Stage • 1 probe gimble • 15 foot encoder cable with your choice of connector • Spare parts kit

OPTIONS
<ul style="list-style-type: none"> • Green laser line kit • Optional 8 and 12" arms. Longer arms available upon request • TOFD transducers & wedges • UT cables • Irrigation supplies

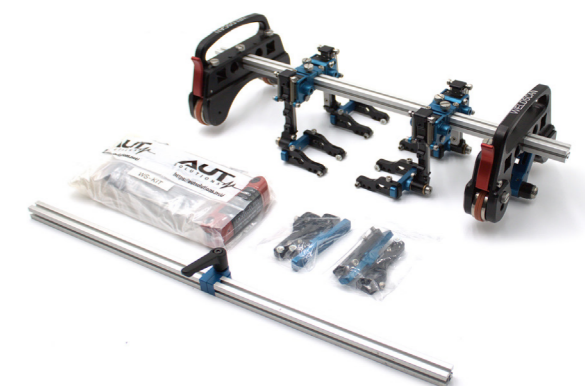

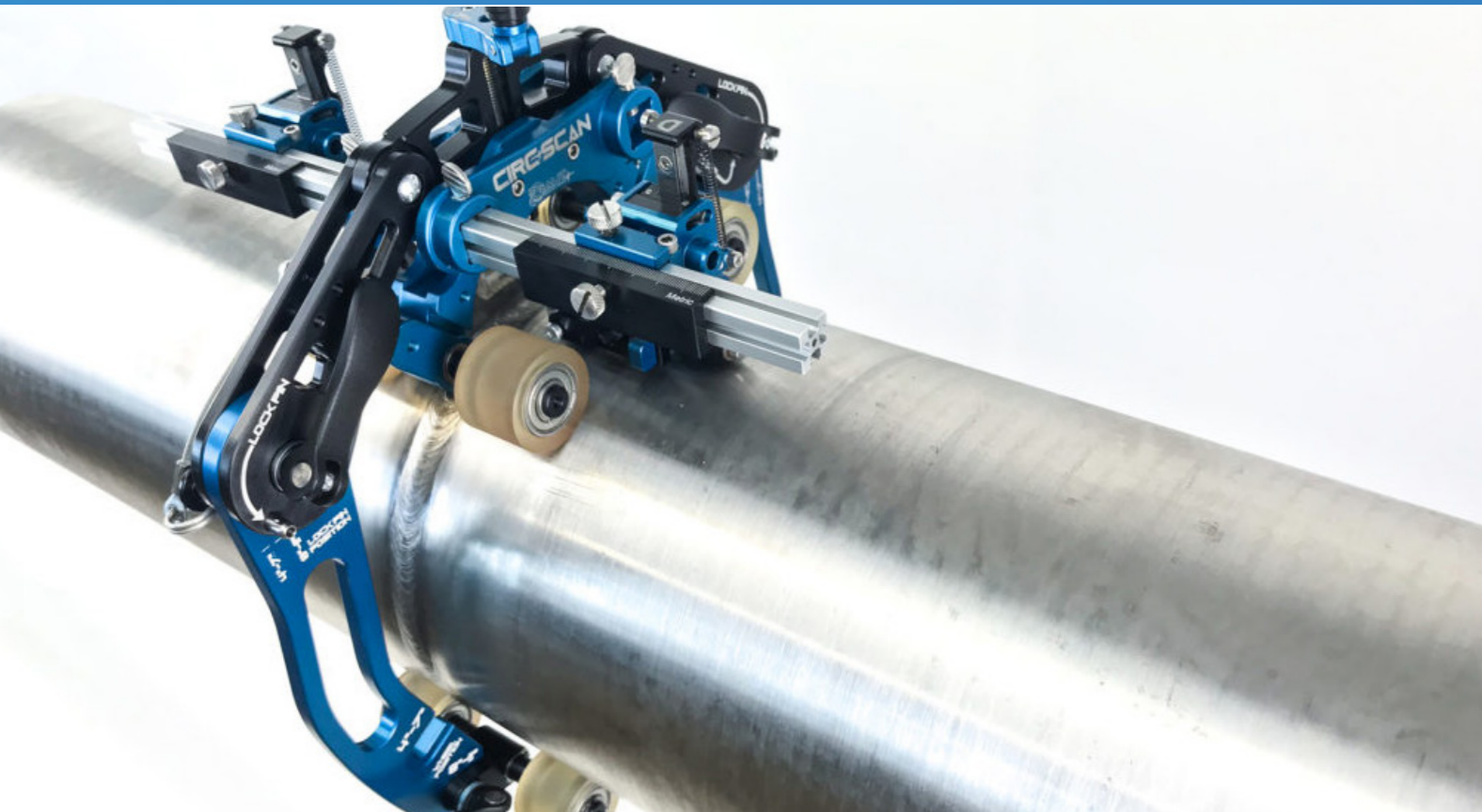

CIRC-SCAN

Modular pipe scanner for multi-purpose inspection

The Circ-Scan is the ultimate scanning solution for weld and corrosion inspections of non-ferrous piping such as stainless steel and HDPE.

- 1 scanner addressing multiple applications
- Minimum training operation, easy fix & adjustment
- Competitive price
- Rugged for field use
- Compatible with all probes & flaw detectors
- Worldwide support

Proven excellence for inspection of circumferential welds and corrosion mapping on pipes and pressure vessels

CIRC-SCAN

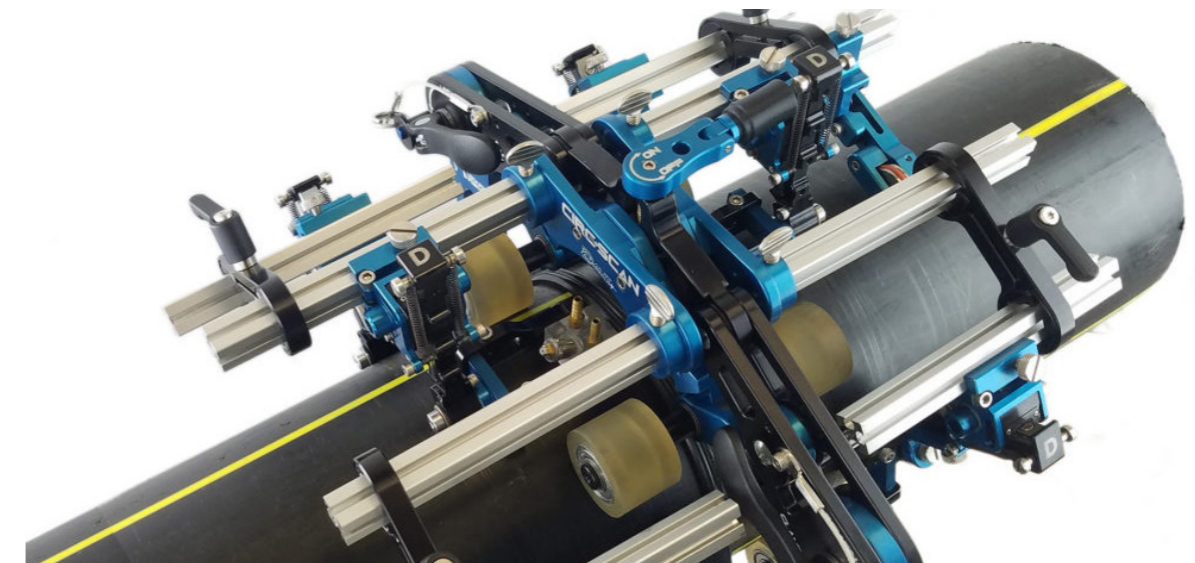

19" - 24"
48 - 61 cm



12" - 18"
30 - 46 cm



4" - 11"
10 - 28 cm

Features

- **Multi-applications** – for corrosion and multi-probe weld inspections
- **Versatile** - allows for scanning on ferrous & non-ferrous pipe from 4" to 36"
- **Easy-to-use** – quick & adjustable clamp design w/o multiple chain links
- **Compatible** – universal UT & PAUT probe holders & encoder connection
- **Modular** – various available kits according to your application

→ TECHNICAL SPECIFICATION

GENERAL	
Scanner dimensions	24 x 10 x 16" 61 x 25.4 x 41 cm
Weight	7.7 lbs / 3.5 kg
Operating environment	Up to 150°F / 66°C
Encoder type	RME-688-1000p
Encoder resolution	1257.33 ticks / in 49.5 ticks / mm
Encoder cable	5 m
Circumferential OD	From 4" to 36" (10 to 61 cm)
Travel case dimensions	24 x 16 x 10.5" 61 x 41 x 25.4 cm

BASIC KIT INCLUDES	
<ul style="list-style-type: none"> • Scanner truck • RME encoder with 5m cable • 3 pairs of arms from 4 to 24" • 2x Clamping wheel trucks • 2x Stage-1 probe gimbles • 2x 6" bars & 2x 12" probe bars • Metric and Imperial PCS scales • Spare parts kit • Travel case 	
BASIC KIT INCLUDES	
<ul style="list-style-type: none"> • Arms extension up to 36" (91 cm) 	



REVOLVER

The small-diameter scanner that fits everywhere

Simply select the band and wedge size as required and within minutes you are ready to scan.

- **Multi-techniques** – designed for PAUT, TOFD, B-Scan, Short Range Guided Wave inspection
- **Adjustable** – inspect pipe from 0.8" to 4.5", up to 8" with additional bands
- **Low profile** – allows to operate between obstructions as low as 0.75"
- **Easy-to-use** – ready to scan within minutes
- **Compatible** – universal probe holders & encoder connection
- **Modular** – various available kits according to your application
- **Rugged** – with high grade anodized aluminium parts with IP68 rated encoder for improved durability

Proven excellence for inspection of small diameter pipes.

REVOLVER

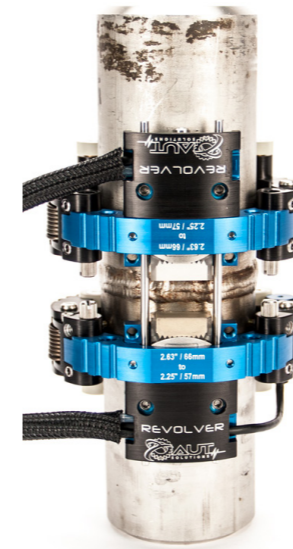

Advantages

- Minimum training operation, easy fix & adjustment
- Competitive price
- Rugged for field use
- Compatible with all probes & flaw detectors

→ TECHNICAL SPECIFICATION

GENERAL	
Scanner dimensions	6 x 3.25 x 2.25" 15.2 x 8 x 5 cm
Weight	1lb / 0.5 kg
Operating environment	Up to 200°F / 94°C
Encoder resolution	2522 ticks / in 99.3 ticks / mm
Encoder cable length	5 m
Circumferential OD	From 0.8" / 2 cm to 4.5" / 12 cm
Travel case dimensions	16.2 x 12.7 x 6.6" 41 x 31 x 15 cm

STANDARD PACKAGE
<ul style="list-style-type: none"> • 10 bands • 1 PA Probe 7.5 CCEV36-16 with wedges • 1 Encoded Truck • 1 Probe Clamp • Tools • Spare Parts Kits • HD Travel Case

ADVANCED PACKAGE
<ul style="list-style-type: none"> • 20 bands - size from pipe OD 0.8" to 4.5", expansion kit up to 8" • 2 PA Probe 7.5 CCEV36-16 with wedges • 1 Encoded Truck • 1 Non Encoded Truck • 2 Probe Clamp • 2 Spreader Bars • Tools • Spare Parts Kits • HD Travel Case



Scan to learn more about Revolver

PROBE FORK KIT
<ul style="list-style-type: none"> • Mounts to any existing Revolver • Use as single or dual setups • Fork bars 1 inch long • 4 forks sets for 4 probe setup • Wedge mount 3 mm / 5 mm • Wedge width 25 mm / 1 inch





NANOSCAN

The compact multi-purpose scanner for multi-purpose inspection

The NanoScan is the first multi-functional magnetic wheeled hand scanner designed specially for advanced ultrasonic techniques such as Phased Array, TOFD, B-scan, C-scan and Short Range Guided Wave (SRGW).

- 1 scanner addressing multiple applications
- Minimum training operation, easy fix & adjustment
- Competitive price
- Rugged for field use
- Compatible with all probes & flaw detectors

Proven excellence for weld inspections.

NANOSCAN



Features

- **New Features** – Enclosed drive train, detachable encoder cable, new and improved nozzle attachment, quick detachable gimble
- **Price** – Lowest cost magnetic wheel scanner
- **Design** – Holds most phased array and TOFD probes/ wedges
- **Magnetic wheels** – Strong bond to ferrous materials
- **Encoder** – High resolution, non-contact, waterproof IP68
- **Compatible** – Works with most flaw detectors



Phased Array
Nozzle Inspection



0-degree B-Scan

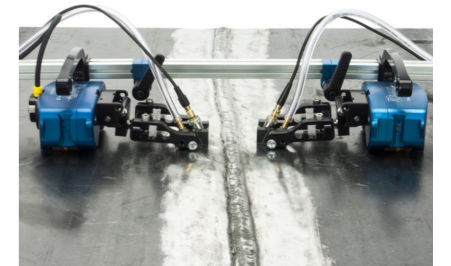

Phased Array
Weld Inspection

→ TECHNICAL SPECIFICATION

GENERAL	
Scanner dimensions	5 x 6 x 3" 12 x 15 x 7.6 cm
Weight	1.5 lb / 0.8 kg
Operating environment	Up to 500°F / 260°C
Encoder resolution	766 ticks / in 30.15 ticks / mm
Encoder cable	5 m
Circumferential OD	4 up to 24" 10 up to 61 cm
Travel case dimensions	15 x 12 x 7" 38 x 31 x 18 cm

BASIC KIT INCLUDES
<ul style="list-style-type: none"> • Kit 1 - Encoded truck and gimble • Kit 2 - Encoded truck, gimble, nozzle attachment • Kit 3 - Encoded & idler truck, 2 gimbles • Kit 4 - Encoded & idler truck, 2 gimbles, nozzle attachment

OPTIONAL ACCESSORIES
<ul style="list-style-type: none"> • Secondary truck and gimble assembly, perfect for dual phased array and TOFD inspections • Nozzle bracket • Phased array and TOFD probes & wedges



MATRYX XY



MATRYX XY

The lightweight panel mapping solution

- Ideal for panel inspection (metallic and composite)
- Super lightweight for easy deployment
- Easy to use with suction cups / magnetic fixtures
- Rugged for field use
- Scaled mapping with 2-axis encoding
- Compatible with all probes & flaw detectors

Proven excellence for composite panel inspection.



→ TECHNICAL SPECIFICATION

GENERAL	
Weight	6.6 lb / 3 kg
Flexible track length	780 mm
Carbon arm length	800 mm
Track minimum curvature	ND 1500 mm and on
Cart connector	Lemo10F
Default adaptor cable	Lemo10M to Lemo16F

INCLUDED IN THE KIT	
• Flexible Rail (780mm)	
• Carbon arm (800mm)	
• Probe holder Ø8mm	
• XY cart	
• Magnetic fixture	
• Suction cups fixture & vacuum pump	
• 3-meter long encoder cable, LEMO 10	
• Carrying case	

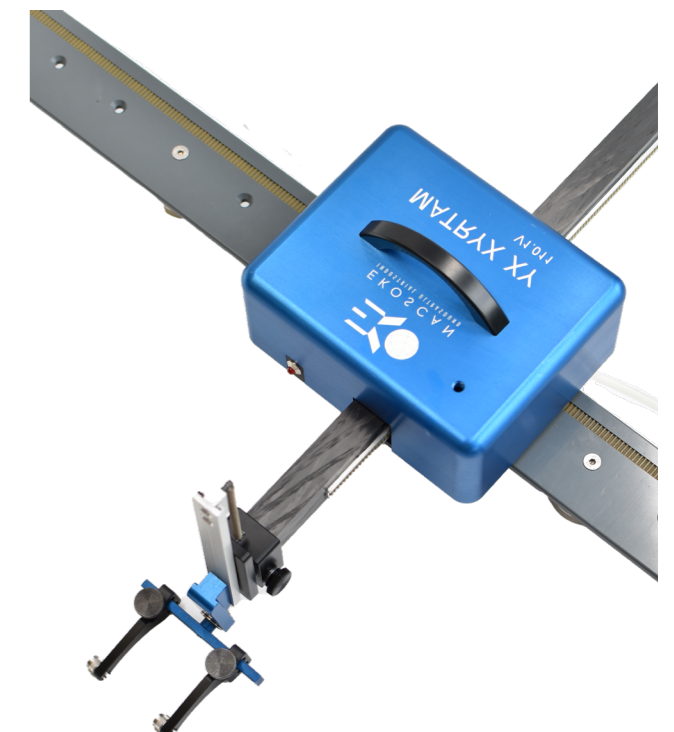



MATRYX RT

The lightweight paint-brush scanner

- Ideal for panel inspection (metallic and composite)
- Super lightweight for easy deployment
- Easy to use with suction cups / magnetic fixtures
- Rugged for field use
- Scaled mapping with 3-axis encoding
- Compatible with all probes & 3-axis flaw detectors
- Worldwide support

Proven excellence for metallic panel inspection.



MATRYX RT



Polar scanner with 3-axis encoding.

This scanner allows for paintbrush mode inspections. Three axes are encoded: extension (R), rotation (Theta) and Skew (Theta 3). :

- θ axis: 360° rotational support
- R axis : extension carbon composite arm
- $\theta 3$ axis: 360° skewing angle

The rotational support is fixed to the part using suction cups or magnets.

INCLUDED IN THE KIT

- Rotational support
- Carbon-composite arm (830mm)
- Rotational probe holder $\varnothing 8$ mm
- 3-meter encoding cable Lemo10
- Carrying case

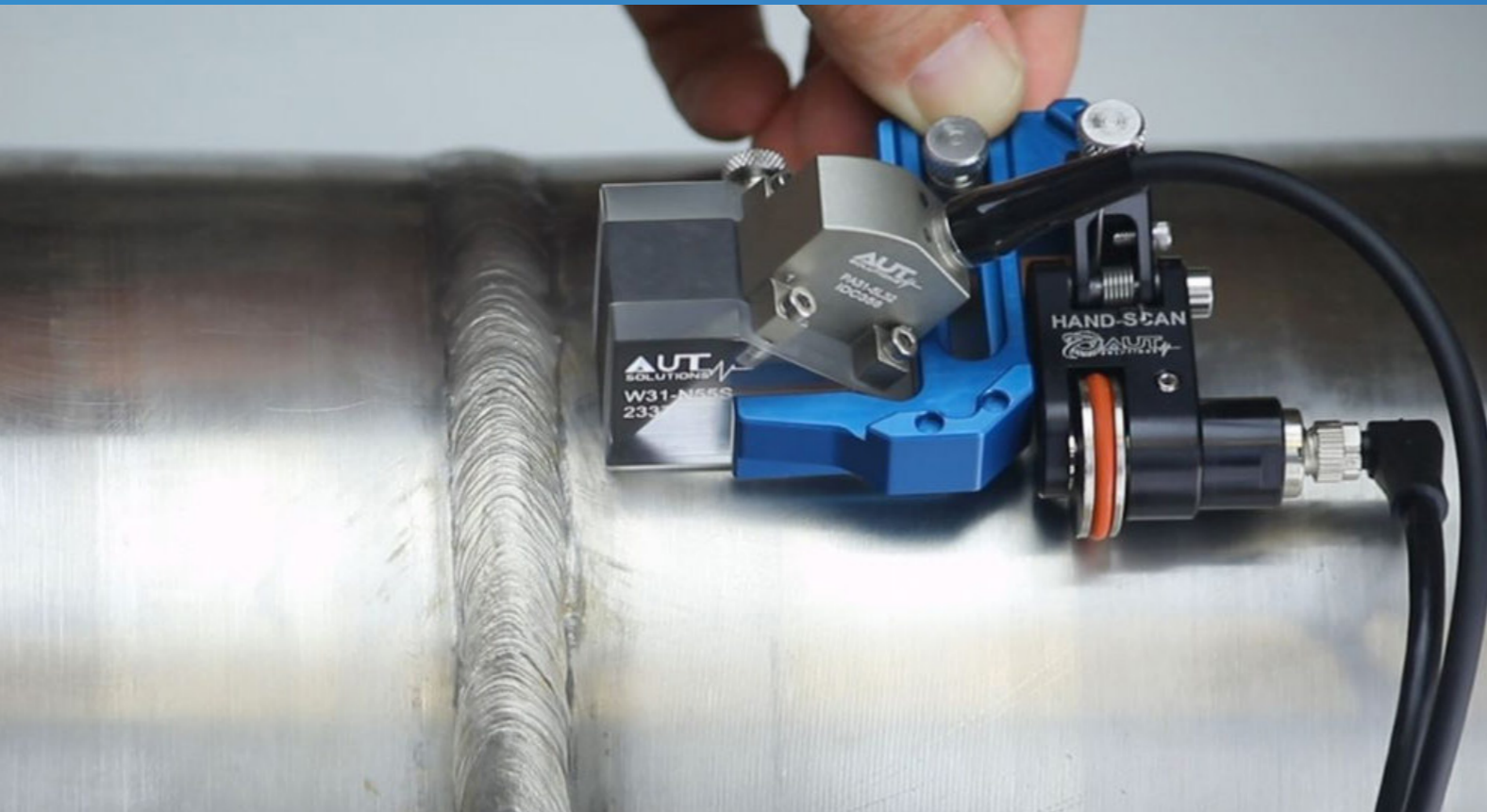

HANDSCAN

The entry-level scanner that gets the job done

Whether for laboratory tests or manual inspection in the field, the HANDSCAN is the ideal scanner for quick and efficient 1-line scanning with PAUT probes, both for weld assessment and limited corrosion areas mapping.

- Easy-to-use – ready to scan within seconds
- Small size - allows to operate in difficult access areas
- Compatible – quick adjustable clamp for wedges up to 56 mm
- Rugged – with high grade anodized aluminium parts with IP68 rated encoder for improved durability

Proven excellence for inspection of circumferential welds and corrosion mapping on pipes and pressure vessels.

HANDSCAN

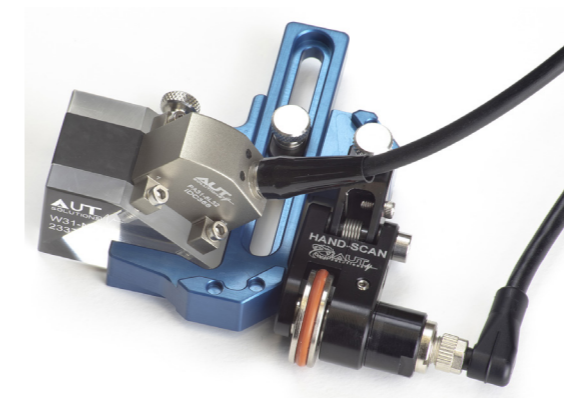

Advantages

- Minimum training operation, easy fix & adjustment
- Competitive price
- Lifetime warranty on the encoder
- Compatible with all probes & flaw detectors
- Five alternate encoder positions to accommodate various inspections

→ TECHNICAL SPECIFICATION

GENERAL	
Scanner dimensions	1.5" x 3.5" x 3.75" 3 x 7.6 x 7.62 cm
Weight	0.32 lb / 0.15 kg
Operating environment	Up to 150°F / 66°C
Encoder resolution	1257.33 ticks / in 49.5 ticks / mm
Encoder cable	5 m
Travel case dimensions	10 x 9 x 3" 25.4 x 23 x 7.6 cm

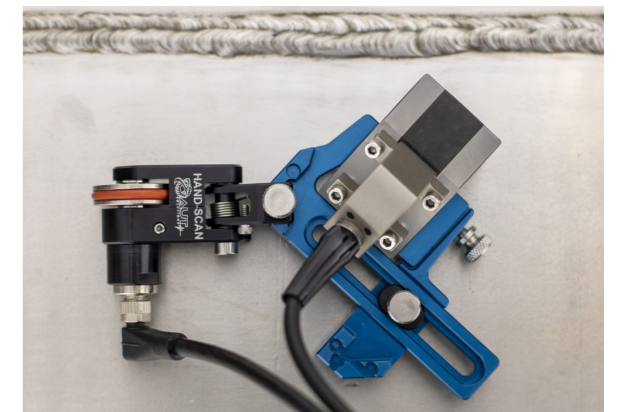

INCLUDED IN THE KIT
<ul style="list-style-type: none"> • HandScan Dual Force Clamp • Spring loaded encoder arm • RME waterproof encoder • 5m encoder cable (connector required) • Protective case

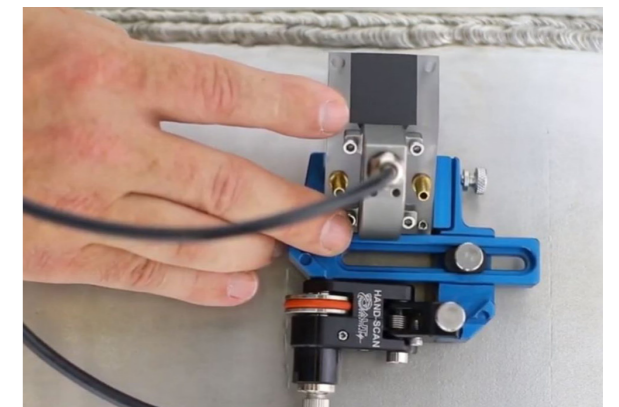

ACCESSORIES
<ul style="list-style-type: none"> • 15 or 30m cable



Scan to see more about
[HandScan](#)



ACCESSORIES

PROSCAN XT

PROSCAN 8

LASER MAPPER

ACCESSORIES



PROSCAN XT

Smallest and most powerful single-channel Ultrasonic flaw detector with 2-Axis encoding

The ProScan is a USB-powered single-channel high-speed acquisition system with advanced ultrasonic tooling and visualizations. It delivers high end performance while remaining user-friendly and cost effective.

Features

- Full Project Stitching – Can run smaller scan sizes for increased productivity then stitch scans for complete inspection view
- DAC Implementation
- TOFD – Tools, Lateral Wave Straightening
- Reporting - Data Export with Grid Control
- Statistics – Find minimum thickness fast
- Data Skewing for angle beam transducers and HIC inspection

Capabilities

- A-scan, B-scan, C-scan, 3D & 4D displays
- Performs Corrosion Mapping, TOFD, & SRGW
- Works with either automated or manual scanners

Analysis

- Statistics, finds min. thickness with one mouse click
- Data exports to Excel with scan increment control
- Image smoothing and hide NRI features



C-Scan Stitching

PROSCAN 8

Eight-channel Ultrasonic Flaw Detector

The Proscan8 takes all the features and benefits of the single channel ProScanXT but now gives you 8 channels. It allows you to collect up to 8 channels of data simultaneously which can increase production and allows you to view data in ways never achieved by other methods such as Phased Array or TOFD.

Capabilities

- All features from ProScanXT but with 8 channels
- Data merging and stitching
- Real time multi-channel fixed angle acquisition

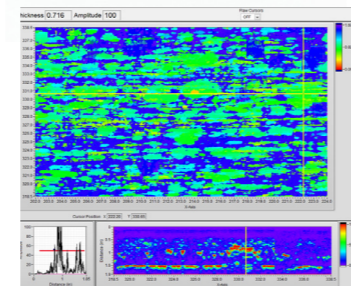

0-degree data showing hydrogen blisters

LASER MAPPER

External Corrosion Mapping Scanner (laser profilometry)

The Laser Mapper makes external corrosion mapping and laser profilometry practical when used in conjunction with our automated scanner systems. The laser beam intensity self adjusts based on variable surface conditions (dull, shiny or in direct sunlight) to obtain a depth reading without loss of data. Scanning speeds can be achieved at speeds up to 30" per second.

Features

- **Fast** - scan up to 30 inches per second
- **Accurate** - to within +/- 0.002 inch
- **Compatible** - works with our existing line of scanners
- **Affordable** - costs less than an automated scanner
- **Portable** - laser sensor and controller weigh less than 2 pounds total
- **Auto-adjusting** laser beam for shiny or dull surfaces

Laser Controller Specifications

- USB Type B
- Laser sensor connector: DB9 male
- Encoder feedback connector: DB9 female
- Voltage : 12vdc
- Current : 100mA

Specifications

- Laser type : Red semi-conductor, wavelength 655nm,
- Laser output 220µW
- Class : FDA Class-1
- Size : 1.9" x 0.85" x 1.3"
- Weight : 120 grams
- Spot diameter: 200µm x 750µm (0.008" x 0.030")
- Repeatability 2µm (<0.001")
- Sensor water sealed to IP67 rating
- Temperature rating -10C to +50C (14 to 131F)
- Acquisition speed : 330µS
- Cable length : 100 ft.
- Sensor stand-off distance : 1" or 25mm
- Measurement range: 1" range (-5mm to 20mm)

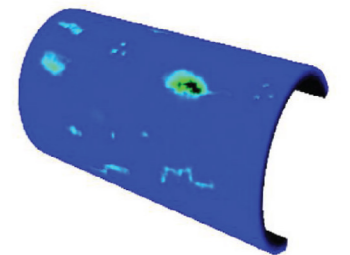

Laser Mapper Surface Scanning



Laser Mapper Surface Scanning

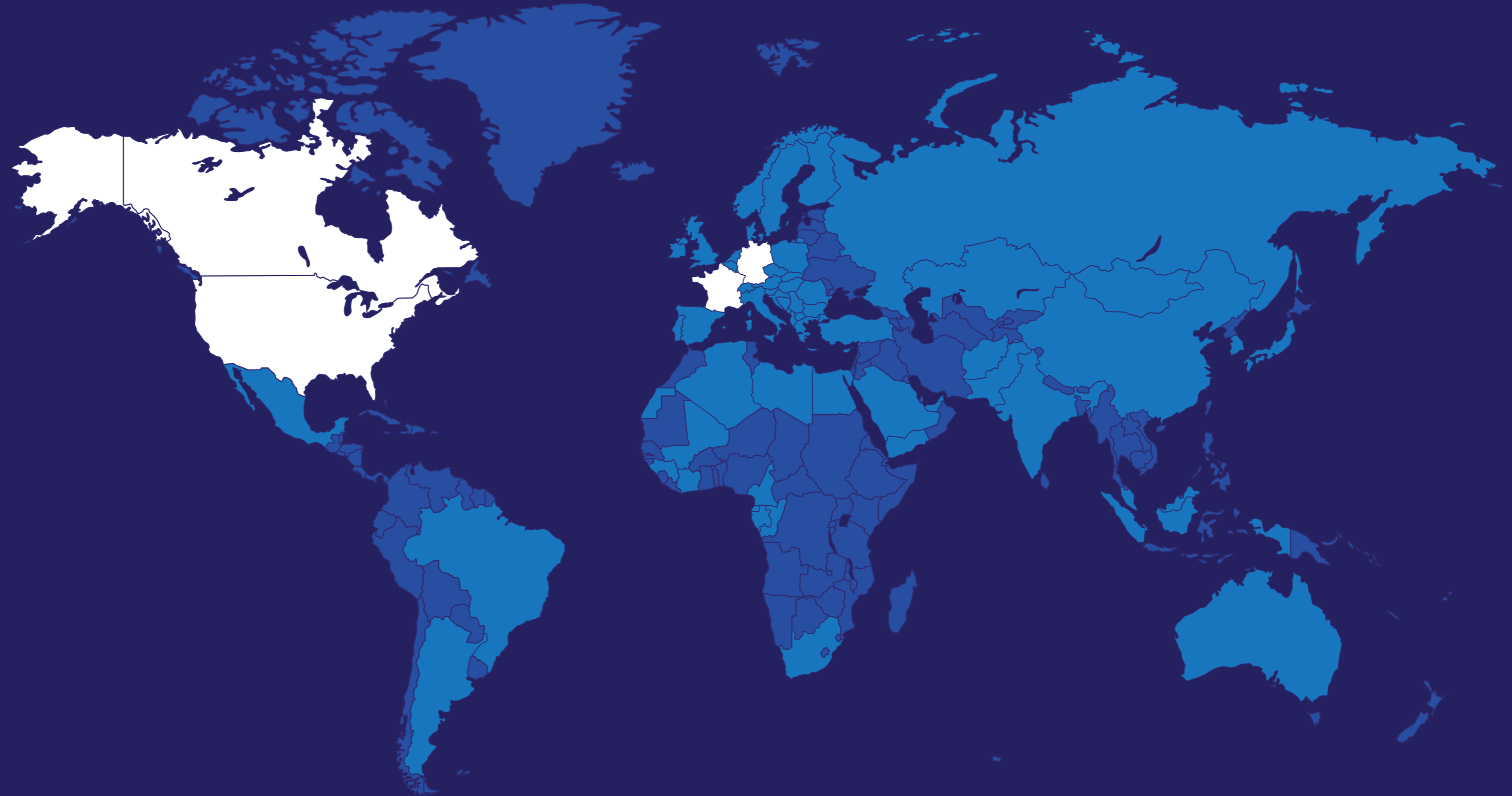

FRANCE

salesFR@ekoscan.fr

GERMANY

salesDE@ekoscan.fr

USA

websales@autsolutions.net

INTERNATIONAL

salesEXPORT@ekoscan.fr

 Physical presence

 Countries served



AUT

AN EKOSCAN COMPANY

YOUR PARTNER FOR SCANNING SOLUTIONS

www.automations.net