

Scalable | Robust | Compliant

Our MFL-DfL Ultra High Resolution (UHR) utilizes state-of-the-art Magnetic Flux Leakage technology to provide feature detection, such as:

- Automated sizing
- Sizing focused
- Sizing + Severity
- Sizing + Correlation
- Manual validation of any given number of indications
- Illegal hot tap locations

MFL-DfL UHR

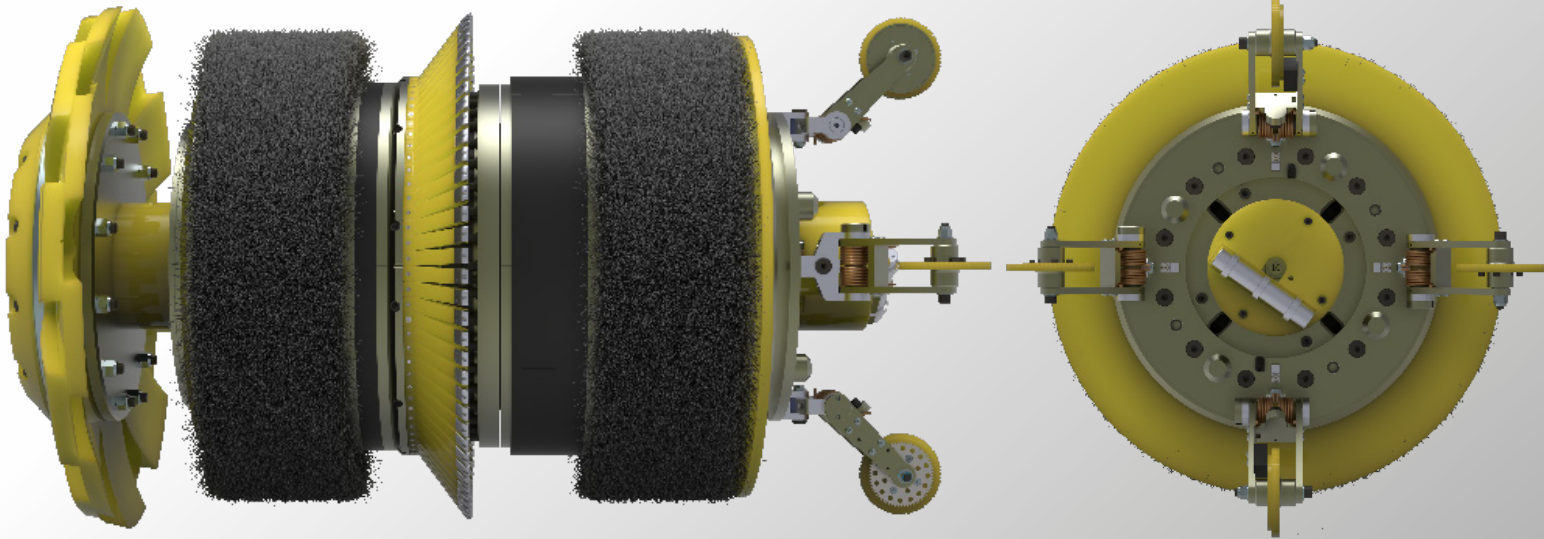

The MFL-DfL UHR Advantage

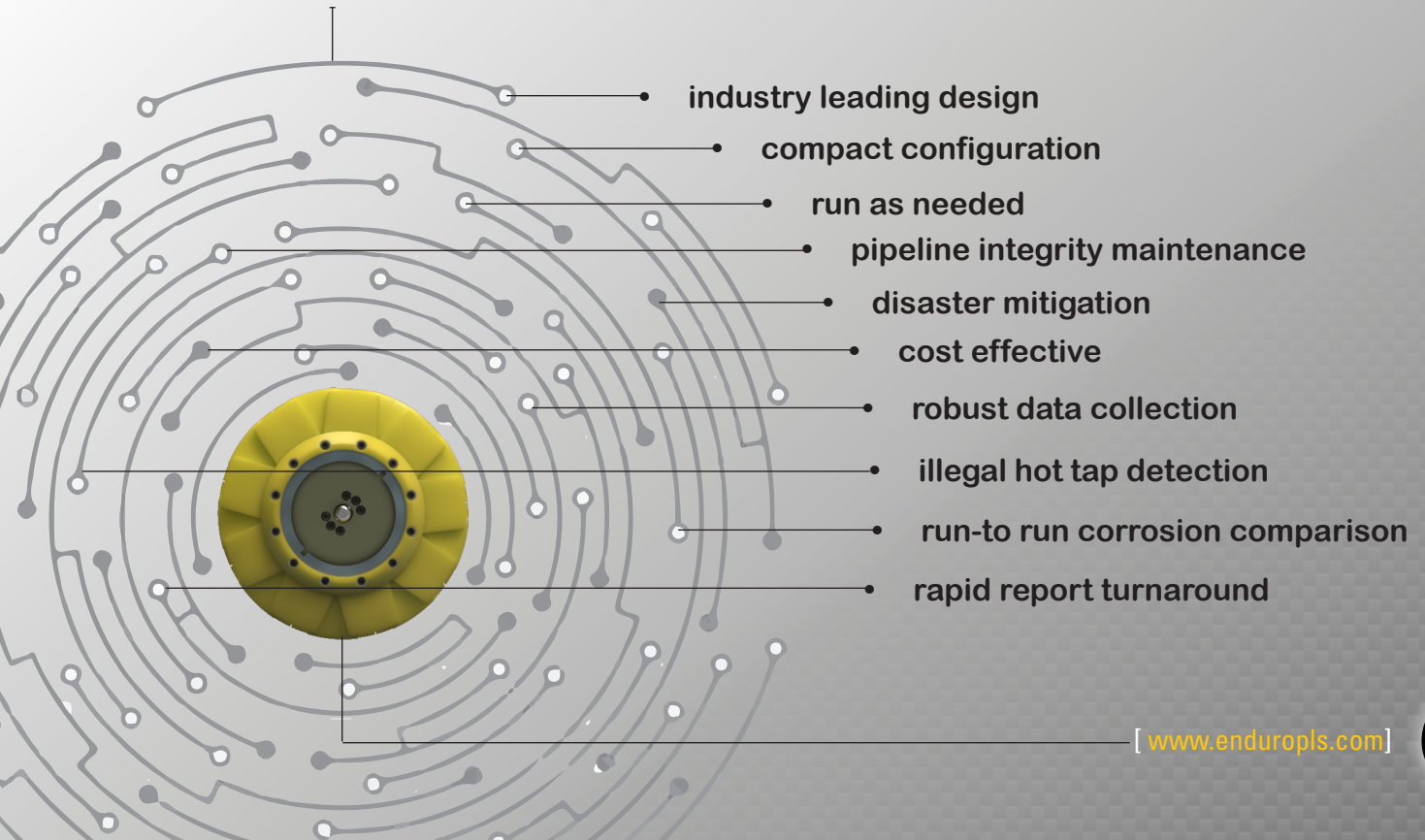

Ensure and maintain the integrity of your pipeline assets frequently

Run our MFL-DfL UHR with an Enduro technician or on your own schedule without one - as often as you desire and receive quick turn-around of your integrity data. Either way, we're here for you every step of the way!

Quick Results

As an excellent option for lines with short launch and/or receive line traps - The data can be quickly examined to determine new features/anomalies and reported to operators for prompt response - saving time and money.

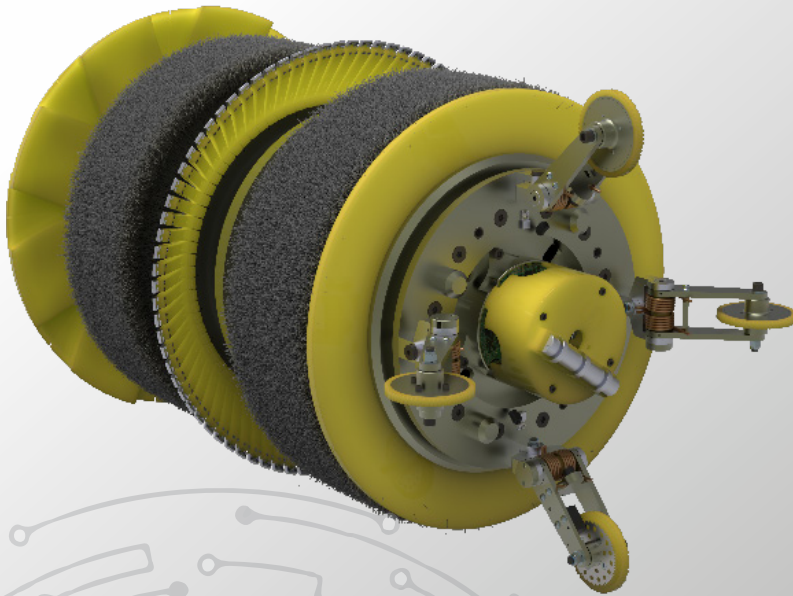

Analysis Comparison

Analysis of the pipeline data can be conducted and compared to previous runs of the MFL detection tools.

A correlation report will identify any new tap features; new features that were not present in previous tool surveys are quickly recognized.

MFL-DfL UHR

ILLEGAL TAPPING
TECHNICIAN-LESS
INTUITIVE MAINTENANCE
VALIDATE & CORRELATE

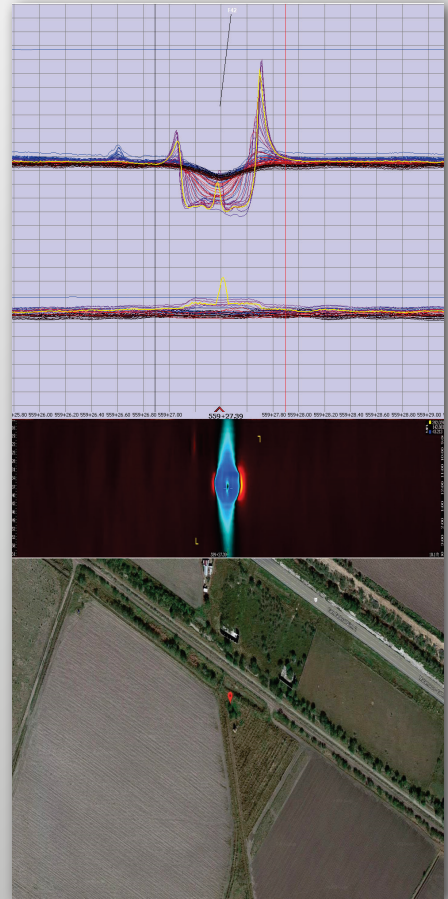

Prevent Catastrophes

By locating and addressing any potential integrity threats immediately, this will mitigate chances of a future catastrophic event.